

OPEN RACKS

Olabs standard 19" EIA Two-Post Open Rack offers flexible choices of 37U, 42U and 45U with optional built-in vertical cable management rails on both sides, suitable for any 19" rack-mountable equipment or patch panels for easy access to cables.

All open racks are made of steel with sturdy structure and are supplied in fully assembled units.

KEY FEATURES :

- Optional built-in vertical cable management rails on both sides
- Space saving footprint with size of 380mm (Depth) x 540mm (Width)
- Extendable built-in vertical cable management rails designed to maximize support of high density patching
- Numbered RU positions for ease of installation
- Ruggedized framework with superior loading and durability

Specifications

Main Material	Steel
Base Dimension (W x D) mm	540 x 380 (base to base)
Loading Capacity	600Kgs
Net Weight	18.1Kgs (37U) 19.3Kgs (42U) 19.9Kgs (45U)
Color & Coating	Black Powder Coating
Compliance	RoHS, EIA
Optional Accessories (To be ordered seperately)	Vertical Cable Manager Horizontal Cable Manager



OPEN RACKS

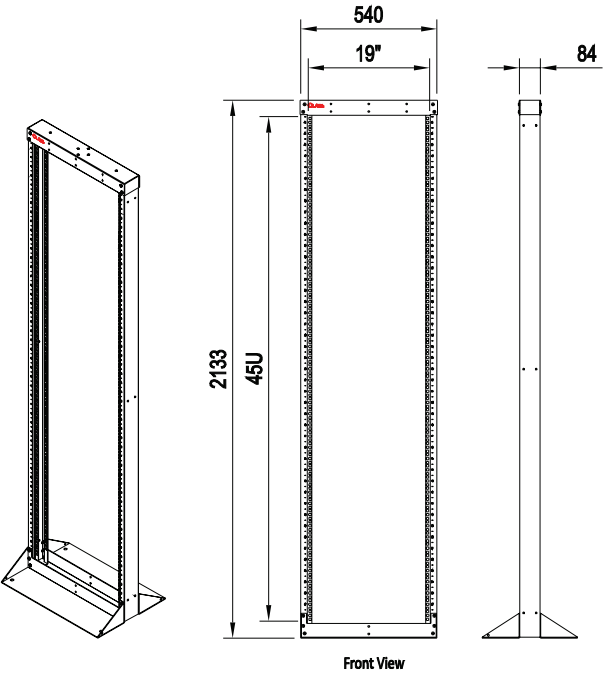

Item Description	Overall Height (mm)	Part No.
Standard 2-Post Open Rack , 37U	1778	ORN37U8B
Standard 2-Post Open Rack , 42U	2000	ORN42U8B
Standard 2-Post Open Rack , 45U	2133	ORN45U8B

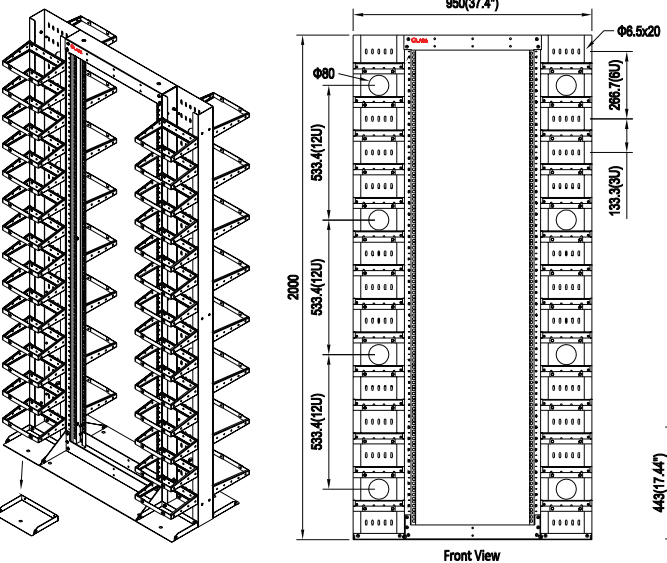

Item Description	Overall Height (mm)	Part No.
2-Post Open Rack , 37U, with Vertical Cable Managers	1778	ORV37U8B
2-Post Open Rack , 42U, with Vertical Cable Managers	2000	ORV42U8B
2-Post Open Rack , 45U, with Vertical Cable Managers	2133	ORV45U8B

RACKS AND CABLE MANAGEMENT

CABINET & RACK SYSTEM